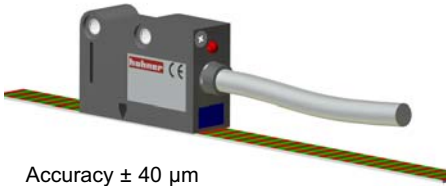
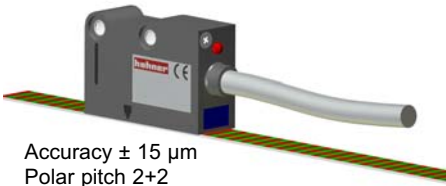
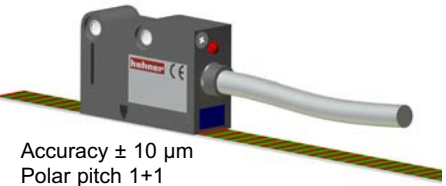

OVERVIEW **MAGNETIC SENSOR**

MSL	MSM	MSH
 <p>Accuracy $\pm 40 \mu\text{m}$ Polar pitch 5+5 Resolution up to $5 \mu\text{m}$ IP67</p>	 <p>Accuracy $\pm 15 \mu\text{m}$ Polar pitch 2+2 Resolution up to $1 \mu\text{m}$ IP67</p>	 <p>Accuracy $\pm 10 \mu\text{m}$ Polar pitch 1+1 Resolution up to $0,5 \mu\text{m}$ IP67</p>

General Information

Incremental magnetic sensors for linear measurement of the MS series allow non-contact, highly precise and real-time measurements. The measuring group is made up of two parts: a sensor that incorporates the electronic capture/an output driver and a polarized magnetic strip in a constant period.

Use is very simple. It consists in moving the sensor without making contact along the strip allowing lengths over 50 metres.

Series of MS magnetic sensors is made up of 3 models, depending on the precision required, with the possibility to incorporate reference signals externally or to the magnetic strip.

Sensor's high IP allows installation in most industrial applications and is ideal for outdoor use.

Range of MS sensors offers an economic and robust alternative to other lineal measurement systems.

Sensor assembly

The sensor can be mounted in any position, keeping the active side, marked by arrows, toward the surface of magnetic strip. Once mounting is carried, place cables and move manually the sensor in the entire run, in order to ensure it can freely slide without any obstacle.

Check that aligning tolerances between sensor and magnetic strip are respected along the whole run. Each positioning error must be corrected.

Dimension of any brackets or supporting arms have to be conveniently calculated; it must be avoided any kind of their bending.

- Proceed to fix magnetic sensor using the M4 threaded holes.
- As an alternative you can use them as passing holes for TCEI M3x18 screws.

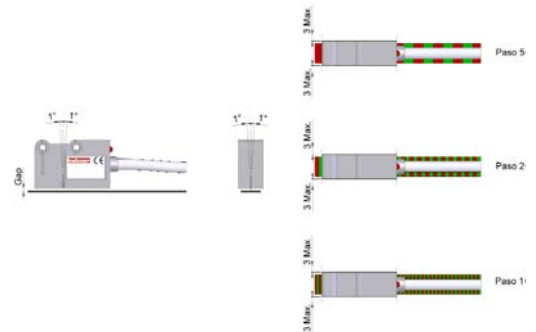

Fixing of magnetic band

Magnetic band can be fixed on any kind of non-magnetic surface.

For a better protection of magnetic band from shavings, liquid sprinklings, powder, etc. we suggest to always use the metal sheet cover PS, already equipped with a double-sided adhesive tape or the aluminium support AP.

The best gluing temperature is between 20 and 30 °C; avoid making it when temperature is below 10°C.

In case of stocking magnetic strip MP200 at a lower temperature than the machine, it is advisable to wait for some hours before gluing. The adhesion of glued parts is completed after at least 48 hours.

Make the gluing of magnetic strip as follows:

- Clean carefully the fixing surface from oil, fat or any kind of dirt, using trace-free solvents.
- Raise up few centimetre of adhesive protection and place magnetic strip, lightly pushing on the initial adhesive zone.
- Proceed with the placing of the strip, removing progressively the adhesive protection and making a uniform pressure. If possible, use a small manual roller.
- Proceed as above to glue the stainless steel cover tape on the magnetic strip, after an accurate cleaning of the surface.
- Use the exceeding part of cover tape for mechanical fixing and "earth" connection of the structure by means of screws TC M3x8.

In order for the system to be more precise, the magnetic strip should be 80 mm (40 mm on each side) longer than the maximum travel of the machine: $L = \text{effective travel} + 80 \text{ mm}$. The tape should be centred along the limit switch.

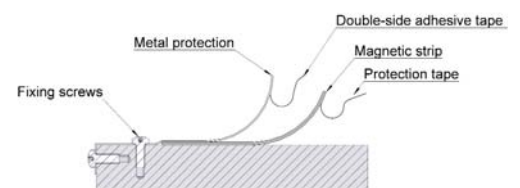

LINEAR MEASURING MAGNETIC SYSTEM

Electrical connections

Sensor is set up with a Line-Driver output. If the reading device cannot read complementary signals, it is necessary to isolate the unused wires one by one. It is important to note that the connection of the unused wires can damage the sensor and it does not guarantee its immunity from interferences.

Make connection when power supply is switched off, and also batteries (when present) are excluded.

Avoid allocating the cable next to any devices which may cause electromagnetic interferences (motors, solenoid valves, inverters).

If some interferences are detected, act on the source of disturb using EMC filters.

If cable extensions are needed, it is necessary to use shielded cables with a section at least 0.35 mm² for power supply and 0.14 mm² for signals.

Verify the correct connection and the continuity of the shield which has to be connected to an earthing node with very low impedance.

Sensor is supplied with a standard cable 2m long. longer lengths can be required.

To balance Line-Driver output, you have to use the following resistance:

- 5V RL=120Ω
- 12V RL=350Ω
- 24V RL=1000Ω

Respect the minimum cable's winding radius of 60mm.

For applications where the max speed reaches more than 1m/sec, the use of a "special cable", suitable to continuous movements, is indispensable.

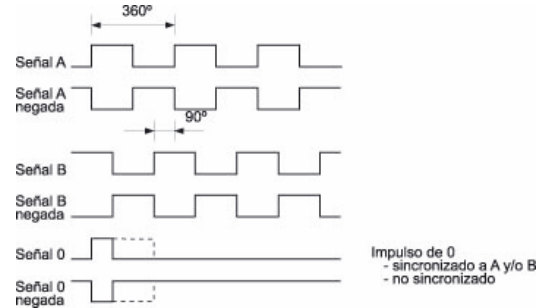

Mounting external zero

The sensor allows the detection of external reference points as well as those included on the magnetic strip (special order). This gives the measurement system the position references necessary for most applications.

The external reference signal is received by installing a magnet (EC) or magnetizing the strip at the desired position(s).

For the installation of the external zero reference (magnet) proceed as follows:

- Both sensor and magnetic strip have to be previously fixed to the machine, in their final position.
- Place the magnet where you need the zero position and move it around 4 mm, until the index red led turns on.
- Place the base of the magnet parallelly to the magnetic strip, at a distance of about 1mm from the sensor. Make the notch, located on the upper part of the magnet, roughly correspond with the vertical one on the body of the sensor.
- Mark on the machine the position of M3 fixing holes of magnet.
- Drill the fixing holes and tighten the magnet by 2 TC M3x12 screws, keeping the active part (magnets) toward the sensor. The slots permit a displacement, parallelly to the magnetic strip, in order to get an accurate positioning of magnet.
- Make a working test in both ways of moving.

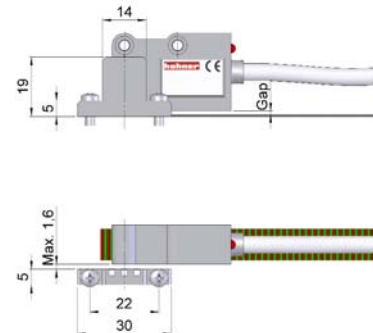

Resistance to chemical agents and maintenance

LOW-IMPACT AGENTS

Formic acid, lactic acid, formaldehyde 40%, glycerine 93°C, hexane, iso-octane, linseed oil, cotton oil, soybean oil, mineral oil.

MEDIUM-IMPACT AGENTS

Acetylene, acetone, acetic acid, oleic acid, stearic acid 70°C, seawater, ammonia, gasoline, ether isopropilic, petroleum, vapor.

STRONG-IMPACT AGENTS

Nitric acid, benzene, dimethylbenzene, tetraethyl furan, nitrobenzene, solvent, toluene, carbon tetrachloride, turpentine, trichlorethylene.

The band and sensor do not need any particular maintenance. An accurate installation, conforming to mounting instructions, and a correct use are sufficient to get a qualitative stability.

In case of malfunctioning please contact the manufacturer for repairing or changing of faulty components. Verify again all mounting tolerances whenever it happens something which can modify the correct alignment of the system.

In order not to compromise the precision of the strip, do not stress it mechanically. Strip has to be rolled always in the same way (active part toward outside), with a diameter not less than 260 mm.

MAGNETIC SENSOR **MSH**

MAGNETIC SYSTEM, LINEAL MEASUREMENT

- Magnetic detection without contact
- Easy mounting
- Resolution up to 0,5 μm .
- Accuracy $\pm 10 \mu\text{m}$
- Polar pitch 1+1
- Protection class IP67
- Metallic cover
- External or integrated zero reference

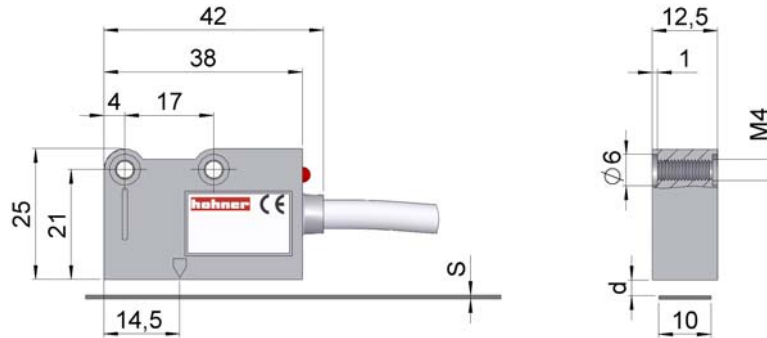
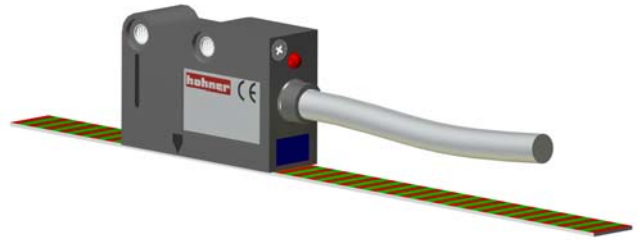

Magnetic band CSH

S (mm)	CSH	CSH + PS*	CSH + AP*
	1.3	1.6	2.1
d(mm)	0,1 + 0,5	-	-

SENSOR SPECIFICATIONS

Resolution	0'5, 1, 5, 10 μm .
Accuracy	$\pm 10 \mu\text{m}$.
Repeatability	± 1 increment.
GAP, distance sensor/band (d) (see previous table)	0,1 a 0,5 mm.
Speed	0,6 m/s (MSH0,5) / 1,2 m/s (other resolutions).
Body	Metallic.
Protection class	IP67.
Operating temperature	-10 .. 70° C.
Storage temperature	-20° .. 80° C.
Humidity	100% not condensed.
Vibration	300 m/s ² (55 + 2000 Hz).
Shock	1000 m/s ² (11ms).
Weight	40g.
Connection	Cable 2 metres.

ALIGNMENT AND SENSOR MOUNTING

■ Sensor - Band



Dimensions in millimeters

hohner
AUTOMATICOS S.L.

ELECTRICAL SPECIFICATIONS

OUTPUT SIGNALS

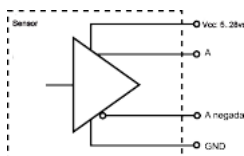

Line Driver

Power supply	5..28v ±5%
Load without charge	Max: 60 mA
Load with charge	140 mA MAX (Vdc= 5v y Z =120Ω) 115 mA MAX (Vdc=12v y Z =1,2kΩ) 90 mA MAX (Vdc=28v y Z =1,2kΩ)
Frecuency	300 kHz
Shortcircuit protection	Yes
Protection against polarity inversion	Yes
Channel A leads 90° electric channel B	

CONNECTION



Cable 3x2x0,14+2x0,34

GND	Blue
Vcc	Red
A	Green
B	White
A inverted	Orange
B inverted	Sky blue
0 (reference)	Brown
0 inverted	Yellow

SENSOR ORDERING CODE

SERIE	RESOLUTION	POWER SUPPLY	SPECIAL CUSTOMER
MSH Polar pitch 1+1	● 0,5- 0,5 μm 1- 1 μm 5- 5 μm 10- 10 μm	● 528- 5..28v	● ●

BAND SPECIFICATIONS

Polar pitch	1+1 mm.
Accuracy at 20°C	± 30 μm/metre.
Width band	10 mm.
Thickness "S" (see table previous page)	1,3 mm.
Maximum length	50 m.
Thermal expansion	10,5 x 10 ⁻⁶ °C ⁻¹ . Tref: 20°C ± 0,1°C.
Bending radius	min. 130 mm.
Operating temperature	-10 .. 70° C.
Storage temperature	-20° .. 80° C.

BAND REFERENCE

SERIE	LENGTH (in mm)	SPECIAL CUSTOMER
CSH	● ● ● ●	● ●

MAGNETIC SENSOR **MSM**

MAGNETIC SYSTEM, LINEAL MEASUREMENT

- Magnetic detection without contact
- Easy mounting
- Resolution up to 1 μm .
- Accuracy $\pm 15 \mu\text{m}$
- Polar Pitch 2+2
- Protection class IP67
- Metallic cover
- External or integrated zero reference

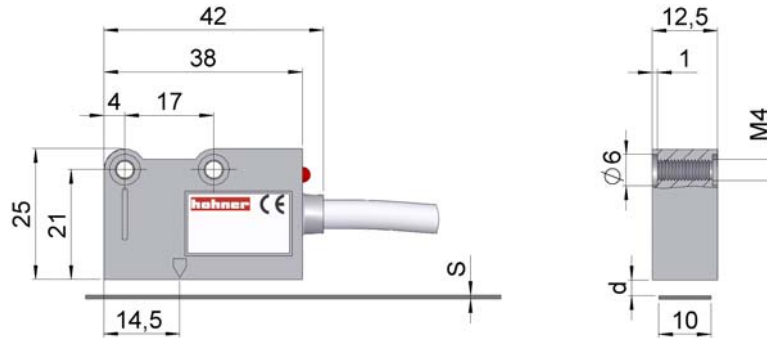
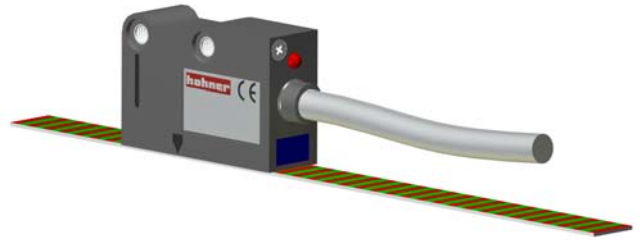

Magnetic band with integrated zero CSMZ

S (mm)	CSMZ	CSMZ + PS	CSMZ + AP
	1,3	1,6	2,1
d(mm)	0,35 + 0,9	0,7 MAX	0,2 MAX

Magnetic band CSM

S (mm)	CSM	CSM + PS*	CSM + AP*
	1,3	1,6	2,1
d(mm)	0,3+1,5	1,2 MAX	0,7 MAX

* PS and AP see accessories section

SENSOR SPECIFICATIONS

Resolution	1, 5, 10, 25, 50, 100, 500 and 1000 μm .
Accuracy	$\pm 15 \mu\text{m}$.
Repeatability	± 1 increment.
GAP, distance sensor/band (d). See previous table)	0,3 to 1,5 mm.
Speed	1,2 m/s (MSM1) / 12 m/s (other resolutions).
Body	Metallic.
Protection class	IP67.
Operating temperature range	-10 .. 70° C.
Storage temperature range	-20° .. 80° C.
Humidity	100% not condensed.
Vibration	300 m/s^2 (55 + 2000 Hz).
Shock	1000 m/s^2 (11ms).
Weight	40g.
Connection	Cable 2 metres.

ALIGNMENT AND SENSOR MOUNTING

■ Sensor - Band

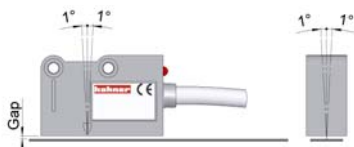

■ Sensor with external zero - Band

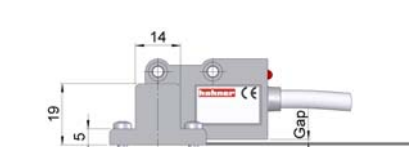

■ Sensor with integrated zero

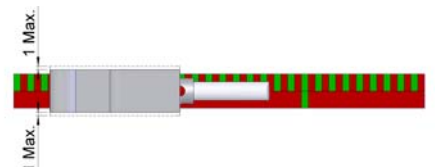
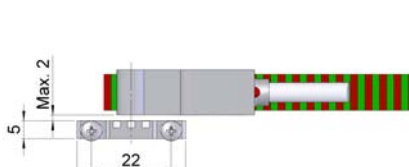
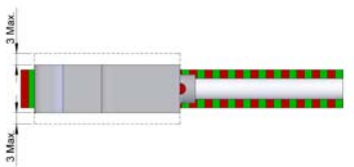
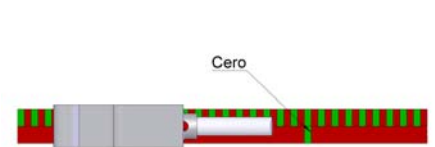

Dimensions in millimeters

ELECTRICAL SPECIFICATIONS

OUTPUT SIGNALS

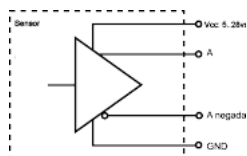

Line Driver

Power supply	5..28v ±5%
Load without charge	Max: 60 mA
Load with charge	140 mA MAX (Vdc= 5v y Z =120Ω) 115 mA MAX (Vdc=12v y Z =1,2kΩ) 90 mA MAX (Vdc=28v y Z =1,2kΩ)
Frecuency	300 kHz
Shortcircuit protection	Yes
Protection against polarity inversion	Yes
Channel A leads 90° electric channel B	

CONNECTION



Cable 3x2x0,14+2x0,34

GND	Blue
Vcc	Red
A	Green
B	White
A inverted	Orange
B inverted	Sky blue
0 (reference)	Brown
0 inverted	Yellow

SENSOR ORDERING CODE

SERIE	RESOLUTION	ZERO	POWER SUPPLY	SPECIAL CUSTOMER
MSM	●	●	●	● ●
Polar pitch 2+2	1- 1 µm 5- 5 µm 10- 10 µm 25- 25 µm 50- 50 µm 100- 100 µm 500- 500 µm 1000-1000 µm	E- External Z- Integrated	528- 5..28v	

BAND SPECIFICATIONS

Polar Pitch	2+2 mm.
Accuracy to 20°C	± 30 µm/metre.
Width band	10 mm.
Thickness band "S" (See table previous page)	1,3mm.
Maximum length	50 m.
Thermal expansion	10,5 x 10 ⁻⁶ °C ⁻¹ . Tref: 20°C ± 0,1°C.
Bending radius	min. 130 mm.
Operating temperature	-10 .. 70° C.
Storage temperature	-20° .. 80°.

BAND ORDERING CODE

SERIE	ZERO	LENGHT (in mm)	ZERO POSITION (in mm)	SPECIAL CUSTOMER
CSM	●	● ● ● ● ●	● ● ● ● ●	● ●
	- : Without zero Z : Integrated			

ACCESSORIES

Cover for band protection : PS

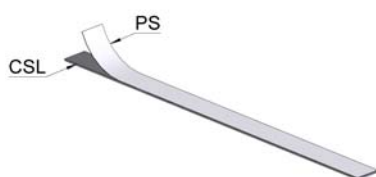

External zero : EC

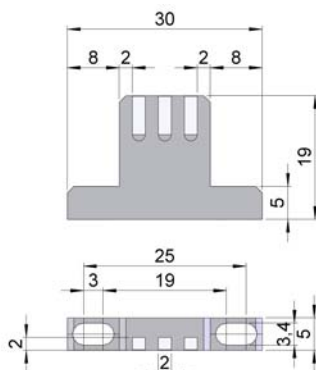

Aluminium support : AP

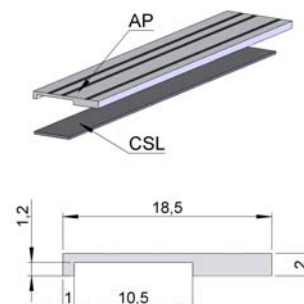

MAGNETIC SENSOR **MSL**

MAGNETIC SYSTEM, LINEAL MEASUREMENT

- Magnetic detection without contact
- Easy mounting
- Resolution up to 5 µm.
- Accuracy ± 40 µm
- Polar Pitch 5+5
- Protection class IP67
- Metallic cover
- External or integrated zero reference

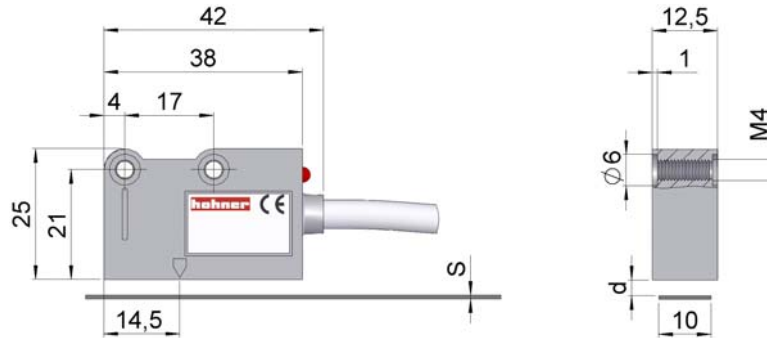
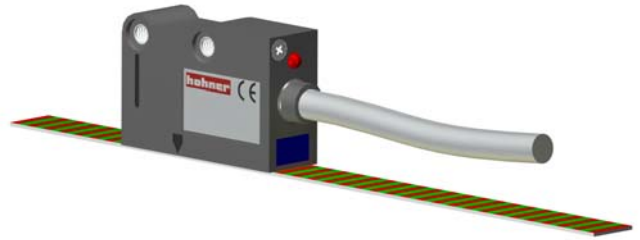

Magnetic band with integrated zero CSLZ

S (mm)	CSLZ	CSLZ + PS	CSLZ + AP
	1.3	1.6	2.1
d(mm)	0,3 + 3,0	2,7 MAX	2,2 MAX

Magnetic band CSL

S (mm)	CSL	CSL + PS*	CSL + AP*
	1.3	1.6	2.1
d(mm)	0.3+3.5	3.2 MAX	2.7 MAX

* PS and AP see accessories section

SENSOR SPECIFICATIONS

Resolution	5, 10, 25, 50 and 100 µm.
Accuracy	±40 µm.
Repeatability	±1 increment.
GAP, distance sensor/band (d) (see previous table)	0,3 to 3,5 mm.
Speed	6 m/s (MSL5) / 12 m/s (other resolutions).
Body	Metallic.
Protection class	IP67.
Operating temperature	-10 .. 70° C.
Storage temperature	-20° .. 80° C.
Humidity	100% not condensed.
Vibration	300 m/s ² (55 + 2000 Hz).
Shock	1000 m/s ² (11ms).
Weight	40g.
Connection	Cable 2 metres.

ALIGNMENT AND SENSOR MOUNTING

■ Sensor - Band

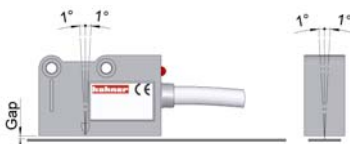

■ Sensor with external zero - Band

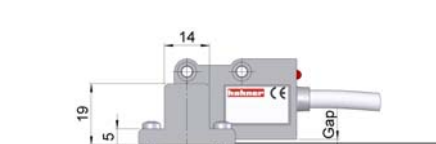

■ Sensor with integrated zero

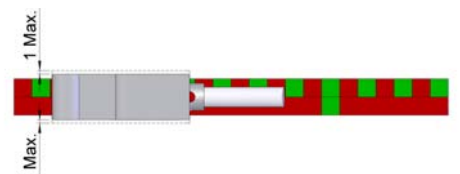
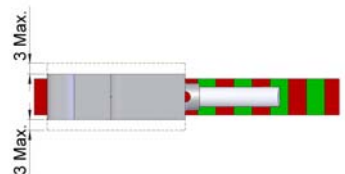
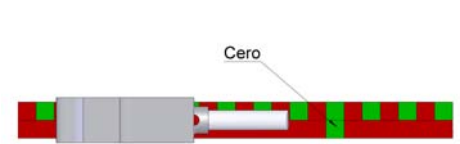

Dimensions in millimeters

ELECTRICAL SPECIFICATIONS

OUTPUT SIGNALS

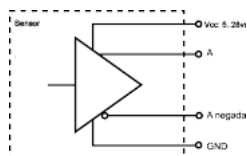

Line Driver

Power supply	5..28v ±5%
Load without charge	Max: 60 mA
Load with charge	140 mA MAX (Vdc= 5v y Z =120Ω) 115 mA MAX (Vdc=12v y Z =1,2kΩ) 90 mA MAX (Vdc=28v y Z =1,2kΩ)
Frecuency	300 kHz
Shortcircuit protection	Yes
Protection against polarity inversion	Yes
Channel A leads 90° electric channel B	

CONNECTION



Cable 3x2x0,14+2x0,34

GND	Blue
Vcc	Red
A	Green
B	White
A inverted	Orange
B inverted	Sky blue
0 (reference)	Brown
0 inverted	Yellow

SENSOR REFERENCE

SERIE	RESOLUTION	ZERO	POWER SUPPLY	SPECIAL CUSTOMER
MSL	●	●	●	● ●
Polar pitch 5+5	5- 5 μm 10- 10 μm 25- 25 μm 50- 50 μm 100- 100 μm	E- External Z- Integrated	528- 5..28v	

BAND SPECIFICATIONS

Polar pitch	5+5 mm.
Accuracy at 20°C	± 30 μm/metro.
Width band	10 mm.
Thickness band "S" (see table previous pag)	1,3 mm.
Maximum length	50 m.
Thermal expansion	10,5 x 10 ⁻⁶ °C ⁻¹ . Tref: 20°C ± 0,1°C.
Bending radius	min.130 mm.
Operating temperature	-10 .. 70° C.
Storage temperature	-20° .. 80° C.

BAND SPECIFICATIONS

SERIE	ZERO	LENGHT (in mm)	ZERO POSITION (in mm)	SPECIAL CUSTOMER
CSL	●	● ● ● ● ●	● ● ● ● ●	● ●
	- : Without zero Z : Integrated			

ACCESSORIES

Cover for band protection : PS

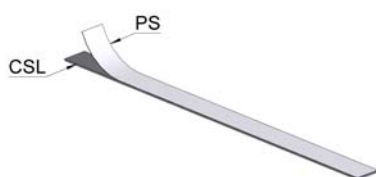

External zero: EC

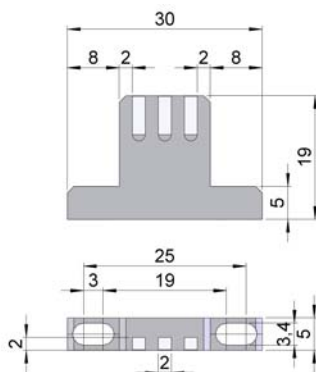

Aluminium support : AP

