

POTENCIOMETER **POT58**

SOLID SHAFT ANGULAR SENSOR FOR INDUSTRIAL APPLICATIONS

- External diameter 58 mm
- Shaft 6 or 10mm
- Protection class IP65 according to DIN 40050
- Measuring range 360°/3600°/7200°
- Current, voltage or resistance output
- Cable connection (any length of cable available) or industrial connector
- Measuring system using accuracy potentiometer

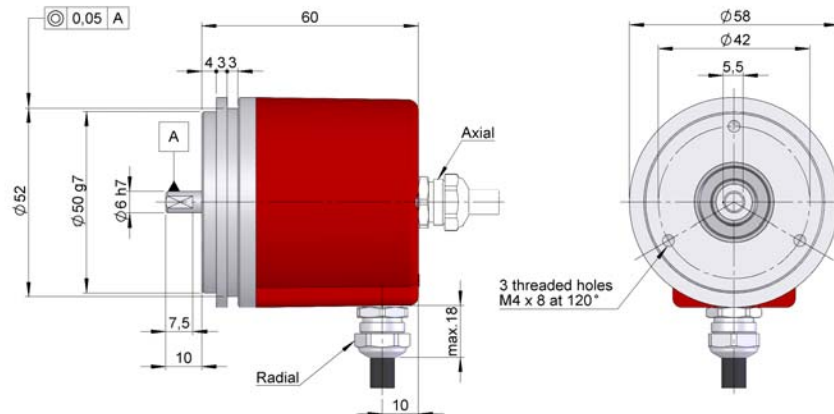

MECHANICAL SPECIFICATIONS

Housing	Aluminium.
Shaft	Stainless steel.
Bearings	Balls.
Maximum load permitted on axial shaft	40 N.
Maximum load permitted on radial shaft	60 N.
Bearings lifetime	1x10 10 rev.
Starting torque	2,0 Ncm.
Output	Potenciometer, analog.
Linearity	See table.
Temperature range	-20°C..+85°C.
Direction	Clockwise.
Protection class according to DIN 40050	IP65.

ELECTRICAL SPECIFICATIONS

	1 kΩ or 10 kΩ 1 turn	1 kΩ or 10 kΩ 10 turns	0..10v	4..20mA
Voltage supply	30 Vdc max	30 Vdc max	15..30 Vdc	15..30 Vdc
Accuracy	± 15%	± 5%	± 0,3%	± 0,3%
Linearity	± 2 %	± 0,25 %		
Thermal coefficient	± 50ppm/C°	± 50ppm/C°	± 50 ppm/°C	± 50ppm/C°
Load	1w max.	2w max.	5 kΩ min.	600Ω max.

OUTPUT

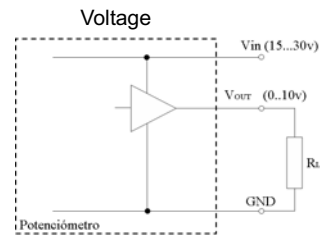
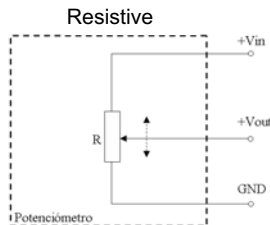
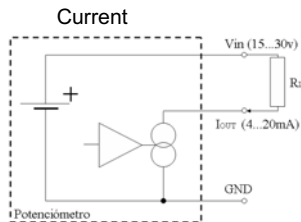

CONNECTION

	Cable 5x0.14	Connector M8 3pin
GND	Yellow	1
V in	White	3
I out	Brown	4

	Cable 5x0.14	Connector M8 3pin
GND	Yellow	1
Vin	White	3
Vout	Brown	4

	Cable 5x0.14	Connector M8 3pin
GND	Yellow	1
Vin	White	3
Vout	Brown	4

ORDERING CODE

SERIE	SHAFT	FLANGE	CONNECTION	ELECTRONIC OUTPUT	MEASURING RANGE
POT58	● 1- Ø10 x 20 mm 2- Ø6 x 10 mm	● 1- None	● 1- Axial cable 2- Radial cable 3- Radial connector M8 3p	● 1- 1 kΩ 2- 10 kΩ 3- 0..10v 4- 4..20mA	90° (1/4 turn) 180° (1/2 turn) 360° (1 turn) 1800° (5 turns) 3600° (10 turns) 7200° (20 turns)

ACCESORIES

